

# XE215C



Hydraulic Excavator



**Engine Model** : ISUZU CC-6BG1TRP  
**Bucket Capacity** : 1.05 m<sup>3</sup>  
**Operation Weight** : 21900 kg  
**Output Power** : 128.5 kW / 2100 rpm

**Head Office Gaya Makmur Putra**  
Jl. Lingkar Luar Barat Duri Kosambi No.1 -Cengkareng  
Jakarta Barat - Indonesia 11740  
Telp : (62 21) 544 8128 / 30  
Fax : (62 21) 544 8131  
Email : [info@gmtractors.com](mailto:info@gmtractors.com)  
Website : [www.gmtractors.net](http://www.gmtractors.net)

# Overall Dimension

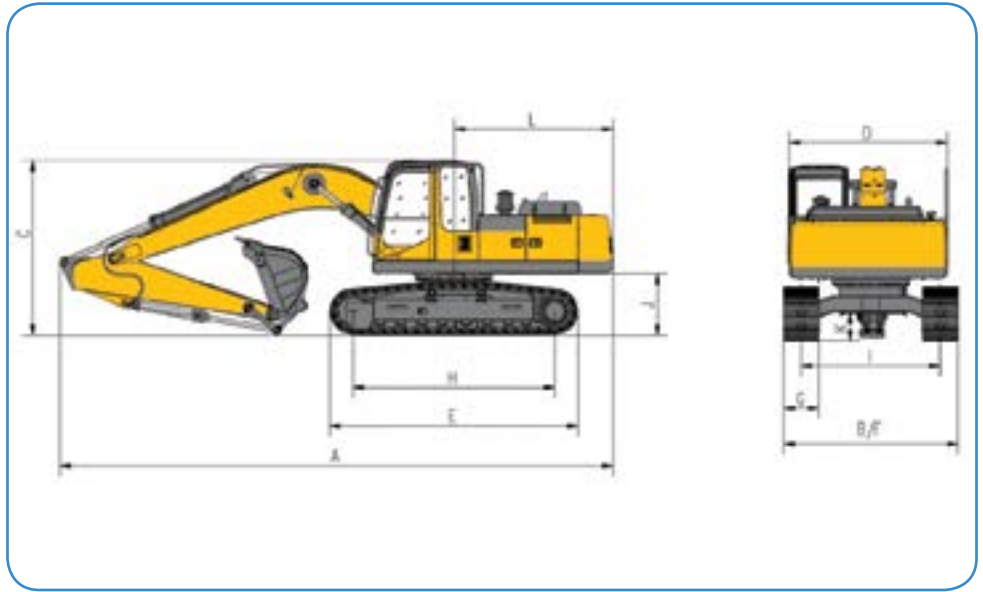
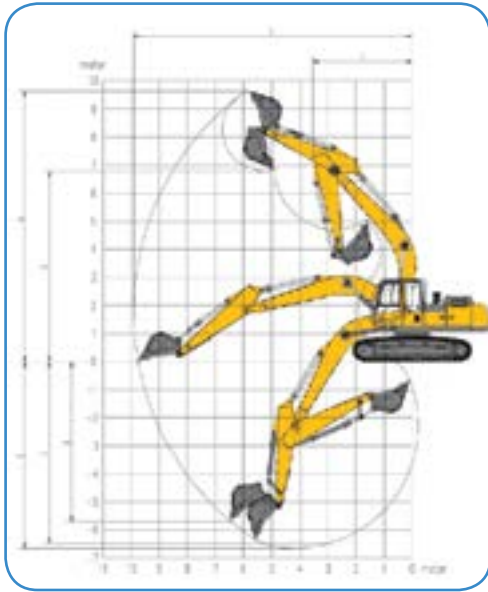

# Main Specification

Item	Spesification
Operating weight	21900 kg
Bucket capacity	0.9-1.0 m <sup>3</sup>
<b>Engine</b>	
Model	ISUZU CC-6BG1TRP
Electric Fuel Injection	√
Four Strokes	√
Water Cooling	√
Turbo-charging	√
Air to air intercooler	√
No. of cylinder	6
Output power	128.5 / 2100 kW/rpm
Torque / speed	637 / 1800 N.m/rpm
Displacement	6.494 L
<b>Main Performance</b>	
Travel speed (H/L)	5.5 / 3.3 km/h
Rotating speed	13.3 r/min
Gradeability	≤35
Ground pressure	47.2 kPa
Bucket digging force	149 kN
Arm digging force	111 kN
Maximum traction	184 kN
<b>Hydraulic system</b>	
Main pump	2
Rated flow of main pump	2x209 L/min
Pressure of prime valve	34.3 / 37.0 MPa
Pressure of travel system	34.3 MPa
Pressure of swing system	28 MPa
Pressure of pilot system	3.9 MPa

<b>Oil Capacity</b>	
Fuel tank capacity	400 L
Hydraulic tank capacity	220 L
Engine oil capacity	25 L
<b>Appearance size</b>	
A. Overall length	9625 mm
B. Overall width	2990 mm
C. Overall height	3100 mm
D. Width of platform	2830 mm
E. Length of crawler	4255 mm
F. Overall width of chassis	2990 mm
G. Width of crawler	800 mm
H. Track length on ground	3462 mm
I. Crawler gauge	2390 mm
J. Clearance under counterweight	1050 mm
K. Min. ground clearance	458 mm
L. Min. tail swing radius	2890 mm
<b>Working scope</b>	
A. Max. digging height	9620 mm
B. Max. dumping height	6780 mm
C. Max. digging depth	6680 mm
D. Excavation depth of 8 feet level	6500 mm
E. Max. vertical wall digging depth	5715 mm
F. Max. digging reach	9940 mm
G. Min. swing radius	3530 mm
<b>Standard</b>	
Boom length	5680 mm
Arm length	2910 mm
Bucket Capacity	1.05 m <sup>3</sup>

THE SPECIFICATIONS ARE SUBJECT TO CHANGE WITHOUT NOTICE. THE PICTURES MAY INCLUDE OPTIONS. THE ACTUAL COLOR & APPEARANCE OF THE PRODUCT MAY DIFFER FROM WHAT IS SHOWN.

## Networking

Surabaya | Medan | Pekanbaru | Palembang | Batam | Balikpapan | Banjarmasin | Makassar | Kendari